

# Ball Valve Full Port

## 3-pc Design



### Features:

- 2000WOG,PN125
- Full Port
- Locking Device Handle Upon Request
- Blow-Out Proof Stem
- PTFE Packing Sealing
- Blance Hole in Ball Slot
- Design Standard:ASME B16.34
- Precision Casting
- ISO5211 Mounting Pad Top Flange
- Testing Standard:API 598/SP-110

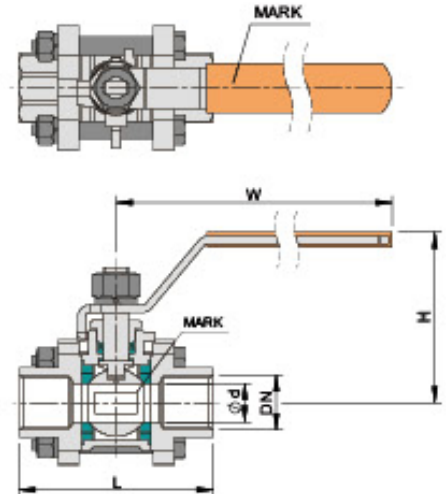

## WR-310/311

1000PSI/PN63

DIMENSION

L\*=DIN3202-M3

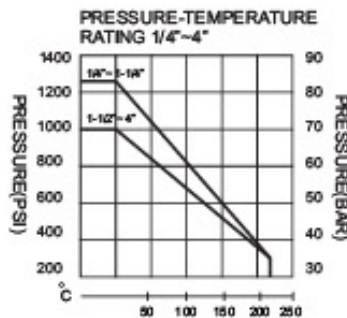

### PRESSURE TESTING

STANDARD PRESSURE	1000PSI
SHELL PRESSURE TESTING	10.4Mpa
WATER SEAL TESTING	7.6Mpa
AIR SEAL TESTING	0.4-0.7Mpa

(unit: mm)

SIZE		L*	L	d	H	W	TORQUE N.M	CV
1/4"	DN8	50	67	12.5	59	100	3.5	2
3/8"	DN10	60	67	12.5	59	100	4	2
1/2"	DN15	75	70	15	61	120	5	3.5
3/4"	DN20	80	80	20	67	125	7	7.1
1"	DN25	90	90	25	74	150	8	12.4
1-1/4"	DN32	110	110	32	82	160	15	20.3
1-1/2"	DN40	120	119	38	99	190	22	28.6
2"	DN50	140	140	49	105	200	25	47.5
2-1/2"	DN65	185	160	63	120	265	50	76
3"	DN80	205	201	76	137	310	85	108.4
4	DN100	240	234	96	157	310	115	198

### DRAWING

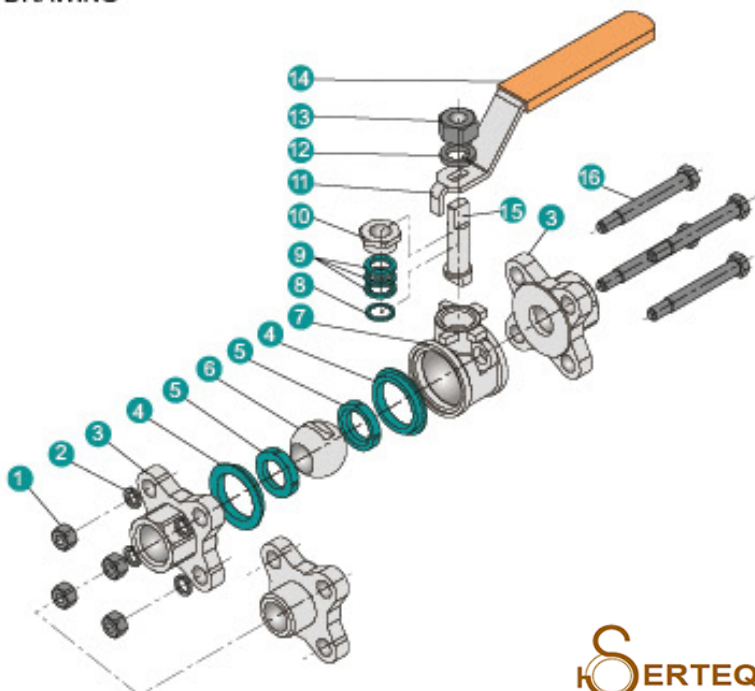

### MATERIAL LIST

ITEM	PART NAME	MATERIAL	
1	NUT	A194-8	
2	SPRING WASHER	SUS304	
3	CAP	CF8M	CF8
4	BODY GASKET	PTFE	R-PTFE
5	BALL SEAT	PTFE	R-PTFE
6	BALL	SUS316	SUS304
7	BODY	CF8M	CF8
8	THRUST WASHER	PTFE	
9	STEM PACKING	PTFE	
10	STOP NUT	SUS304	
11	HANDLE	SUS304	
12	SPRING WASHER	SUS304	
13	STEM NUT	A194-8	
14	HANDLE COVER	PLASTIC	
15	STEM	SUS316	SUS304
16	BOLT	A193-B8	