



J+J

ELECTRIC VALVE ACTUATORS

J3C Series



From J+J - a world-wide brand



New design housing
New models
New functionality
New features

LED Status light

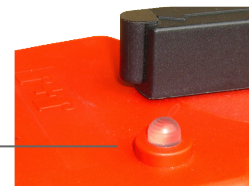

Multi-voltage capable
Manual override
Electronic torque limiter
Anti-condensation heater
External electrical connection



Plug & play function conversion kits

- Failsafe
- Modulating
- Failsafe modulating





J3C Series



Doc: J3C-Cat/Rev01
Oct 2013

Feature rich **J+J** multi-voltage actuator with LED status light and plug & play accessories.

The **J3C** range of electric actuators takes its highly successful predecessor, the **J2** range, to the next level.

With rugged IP67 weatherproof and anti-corrosive Polyamide housing, the **J3C** offers more user-friendly features than the **J2**, and introduces a highly visible LED status light.

This dome visual indicator shows whether the actuator is operating correctly, or has tripped out either by its electronic torque limiter, or has been left in 'manual' mode.

Site operators are no longer left with the 'valve or actuator?' question when an actuator doesn't respond to a signal.

The **J3C** is quick and easy to install, with ISO:5211 multi-flange mounting and a double square drive, allowing fast

mounting to ISO:5211 valves. There is no need to remove the cover to connect the **J3C** electrically, saving installation time.

Using the external DIN plugs and external wiring diagrams supplied with the actuator,



installations can be pre-wired. Protection against valve jams is provided by an electronic torque limiter, which auto-relaxes the gearbox when activated, allowing the manual

override to be selected to assist in clearing the jam.

The effect of condensation is eliminated by an internal thermostatic anti-condensation heater that does not require a separate independent power supply.

Standard function for the **J3C** is power open, power close, stays put on power failure.

However the **J3C** has plug and play accessories –the function can be changed to either failsafe or modulating by fitting the new plug and play conversion kits.

The modulating kit has the new digital positioner that offers auto-calibrating and self resetting functionality. These conversion kits are available as optional extras.

The **J3C** is a very, very smart red box!

Quick guide to the **J3C**'s standard features :

Multi-voltage with auto-voltage sensing.
'L' 12 ~ 24V AC or DC .
'H' 110 ~ 240V AC or DC

LED Status light to indicate operational status of actuator

Electronic over-torque protection against valve jams

Thermostatic anti-condensation heater

Manual override for emergency hand operation

2 Volt free end of travel confirmation switches

IP65 weatherproof anti-corrosive and UV protected Polyamide housing

Local visual position indicator J3C with dome indicator

ISO5211 multi-flange mounting with double square drive

All external electrical connections via supplied DIN plugs

CE marked

ISO 9000 manufacturer

Failsafe and digital positioner plug & play kits available.

J3C Status light functions:

Constantly lit LED

If the actuator is operating correctly with no faults, the LED shows a constantly lit light.

The LED flashes with 2 blinks

If the actuator has been left in 'manual' mode, the actuator's motor runs but doesn't drive the output shaft. After a pre-set time, the actuator knows that as the torque limiter has not activated and that the motor is running, it must be in manual.

The LED flashes on/ off

When the actuator senses an impending valve jam, the electronic torque limiter is activated and on activation, repeatedly flashes the LED on and off.



Specifications:

	Model 20		Model 35		Model 55		Model 85	
	J3C -L20	J3C -H20	J3C -L	J3C -H	J3C -L55	J3C -H55	J3C -L85	J3C -H85
Voltage AC (Iph) or DC	12 - 24	85 - 240	12 - 24	85 - 240	12 - 24	85 - 240	12 - 24	85 - 240
Working time - secs 0-90° (no load) ±10%	12	11	12	11	16	14	35	30
Max run toque Nm In.lbs	20 177	20 177	35 309	35 309	55 486	55 486	85 752	85 752
Max break torque Nm In.lbs	25 221	25 221	38 336	38 336	60 531	60 531	93.5 827	93.5 827
Duty rating %	75	75	75	75	75	75	75	75
IP rating IEC 60529	IP67	IP67	IP67	IP67	IP67	IP67	IP67	IP67
Working angle Std°	90	90	90	90	90	90	90	90
Temp range °C °F	-20 to +70 -4 to +158	-20 to +70 -4 to +158	-20 to +70 -4 to +158	-20 to +70 -4 to +158	-20 to +70 -4 to +158	-20 to +70 -4 to +158	-20 to +70 -4 to +158	-20 to +70 -4 to +158
Motor switch	2 x V3	2 x V3	2 x V3	2 x V3	2 x V3	2 x V3	2 x V3	2 x V3
Volt free end of travel confirmation	2 x V3	2 x V3	2 x V3	2 x V3	2 x V3	2 x V3	2 x V3	2 x V3
Anti-condensation Heater	4W	4W	4W	4W	4W	4W	4W	4W
Current (full load) 12VDC 24VDC 24VAC 110V/Iph 220V/Iph	2.05A 1.00A 0.85A	0.17A 0.09A	3.23A 1.49A 1.07A	0.23A 0.12A	3.08A 1.40A 1.20A	0.24A 0.11A	2.10A 1.20A 0.90A	0.22A 0.09A
Inrush	Max (A) x3	Max (A) x3	Max (A) x3	Max (A) x3	Max (A) x3	Max (A) x3	Max (A) x3	Max (A) x3
Weight Kg	1.8	1.8	1.9	1.9	2.4	2.4	3.0	3.0
ISO:5211	F03,04 & F05	F03,04 & F05	F03, 04, 05 F07 Option	F03, 04, 05 F07 Option	F05 & F07	F05 & F07	F05 & F07	F05 & F07
Output drive (DIN:3337) Double Square drive (Std) (Options) Bespoke (eg: two flats etc)	14 9, 11 Contact us	14 9, 11 Contact us	14 9, 11, 17 Contact us	14 9, 11, 17 Contact us	17 11, 14 Contact us	17 11, 14 Contact us	17 11, 14 Contact us	17 11, 14 Contact us

Optional extras:



BSR kit



DPS kit

Failsafe (BSR) Standard on/off version can be converted to failsafe using a plug & play conversion kit. Failsafe achieved with the use of industrial re-chargeable batteries which are supplied with the BSR conversion kit.

Modulating (DPS) Standard on/off actuator can be converted to modulating using a plug and play conversion kit. The modulating function is achieved with a self calibrating digital positioner (either 0-10V or 4-20mA I/O) supplied with the DPS conversion kit.

Failsafe Modulating (BSR+DPS) Install both kits !

Dimensions:

J3 and J3C outside dimensions are the same



J3C-20

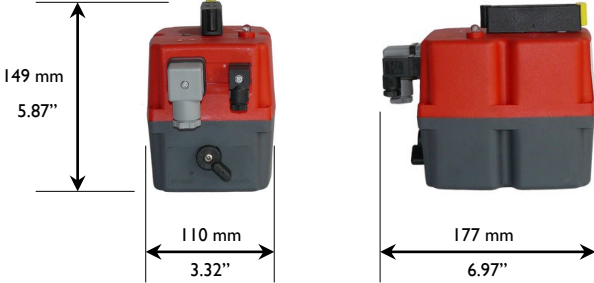

J3C-35



J3C-55

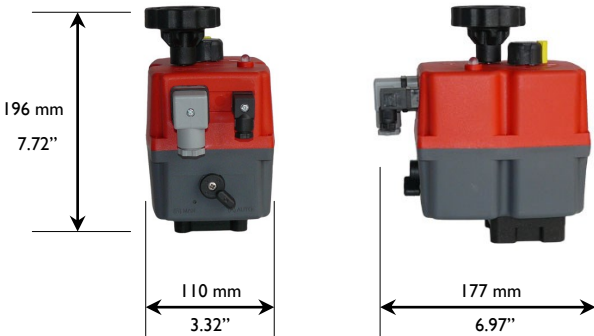

J3C-85

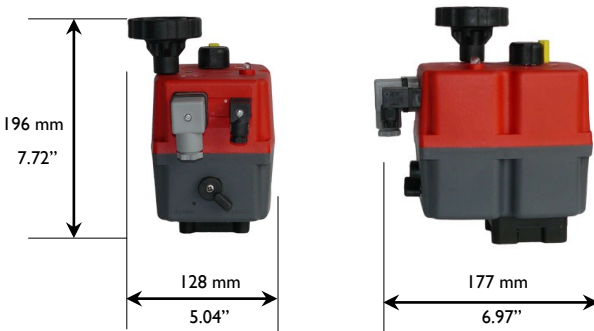

The **J+J** BSR (Battery 'Spring Return') system - what it does and how it works

J+J's BSR system simply provides an alternative power supply to drive the actuator to a pre-set failsafe position in the event of a mains power failure. It has no mechanical springs, it uses internal battery power.



During normal operation the **J3**-BSR operates as a power open - power closed actuator, simultaneously maintaining the industrial re-chargeable battery at full strength from an internal trickle charging system.

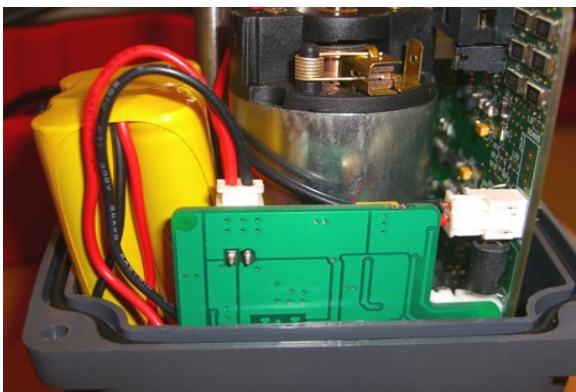

The main advantage of **J+J**'s BSR system is that it is more competitively priced compared to mechanical spring return actuators, as the **J+J** actuator has no mechanical springs to compress, or solenoids to release them - the actuator is the same size as that for an on-off version. This offers massive savings compared to true mechanical spring return electric actuators.

The industrial battery is deliberately oversized and whilst not necessary, can provide many cycles at full load. This offers a degree of protection in the unlikely event that the battery degrades and loses some charge.

In the event of a mains failure, if not already in that position, an internal switch changes to immediately draw battery power to drive the actuator to the failsafe position.



Following a battery driven cycle the actuator will need to charge for a short period to replace the energy used in the battery cycle. This is particularly relevant if you intend to use the **J3**-BSR like a solenoid, eg: energise open, fail close.



The BSR fits inside the **J3** actuator housing eliminating extra piggy-backed housings, making the **J3** failsafe actuator very compact and lightweight. It can be supplied as a retro-fittable kit containing all the parts needed to convert a standard on-off actuator.

The **J+J** DPS (Digital Positioning System) - what it does and how it works

J+J's DPS system provides accurate modulating function whereby the movement of the actuator is controlled by either a 4-20mA or a 0-10VDC control signal. Any change in the control input signal results in a corresponding and proportional change in the position of the actuator.



This is achieved with the use of an internal digital positioning system designed and developed by **J+J**.

The main advantages of **J+J**'s DPS system are that the system is retro-fittable to the standard **J3C** on-off actuator, it is self-calibrating, provides an output signal as standard, and virtually eliminates 'hunting'.

An internal microprocessor on the DPS circuit board continuously monitors digitally the analogue input and output signals and compares them to the physical position via an output shaft feedback system, moving the actuator as required to balance the signals.



Digital control ensures high sensitivity and repetivity, with all the usual positioner characteristics coming in at under 1% (hysteresis, linearity & precision).



The DPS is self calibrating, and on initial start-up or on restoration following a power cut, will go through a short automatic set-up sequence.

In situations where the actuator is used in manual mode (eg: commissioning) and put back into automatic mode with the actuator out of it's normal operating quadrant, the DPS will auto-adjust itself back into the correct quadrant, re-set itself, and be ready for use.

The DPS can be supplied as a retro-fit kit containing all the parts required to convert a standard on-off actuator to a modulating unit, and can be used in conjunction with the **J+J** BSR kit to produce fail-safe modulating functionality.

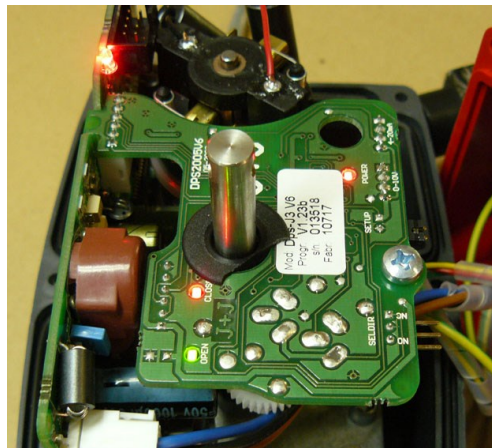

AC (1ph) OR DC SUPPLY - WIRING FOR ON-OFF OR FAILSAFE ACTUATORS

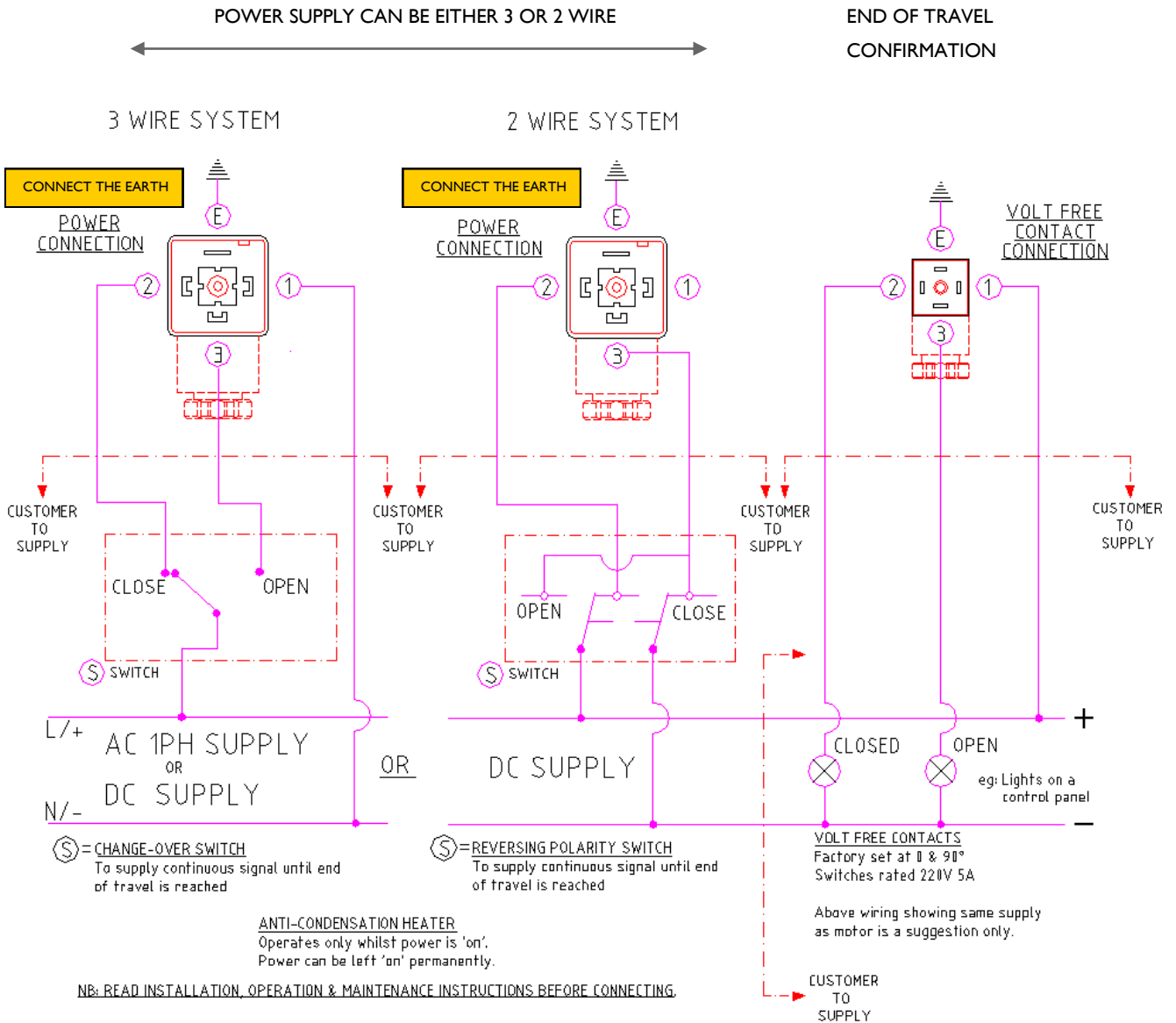

FUNCTION: ON-OFF VERSION

Power open, power close
Stays put on mains power failure

POWER SUPPLY TO BE INDEPENDANTLY FUSED AND NOT LINKED TO OTHER EQUIPMENT

FUNCTION: FAILSAFE VERSION

Power open, power close - trickle charges battery system in either open or closed position
Actuator sent by battery power to pre-set failsafe position on power failure
Actuator returns to pre-failure position on power resumption.
Failsafe can be either NC (normally closed) or NO (normally open)

POWER SUPPLY TO BE INDEPENDANTLY FUSED AND NOT LINKED TO OTHER EQUIPMENT

AC (Iph) OR DC SUPPLY - WIRING FOR MODULATING ACTUATORS

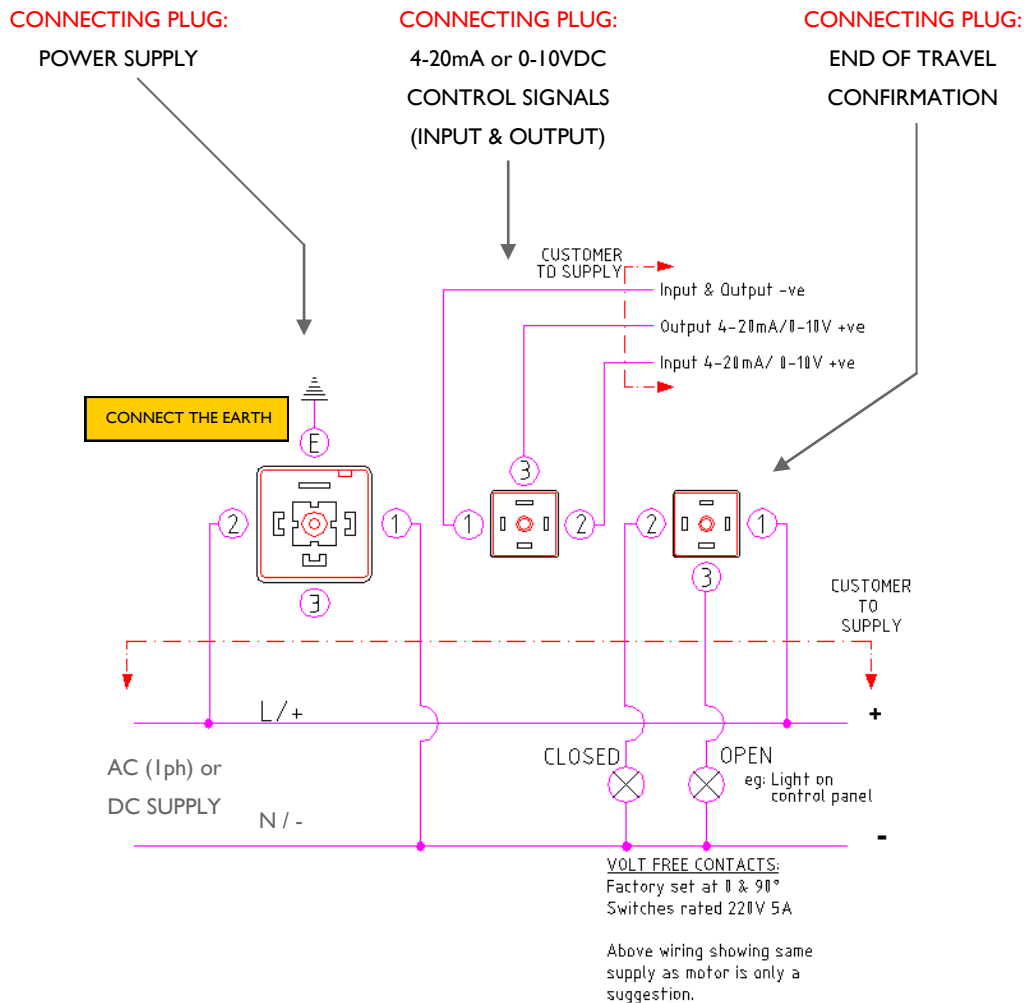

FUNCTION: MODULATING VERSION

Power open, power close - actuator movement controlled by input signal (4-20mA or 0-10VDC)
 Standard operation: 4mA or 0V = actuator closed, 20mA or 10V = actuator open (can be reversed)
 Standard operation: Actuator closes on loss of control signal, stays put on loss of mains power
 Output signal (in same format as supply signal) provided as standard.
 Do not connect the earth in the control plug.



Travessa da Prelada, n.º 106 | 4250-379 Porto
 GPS N41.169040 W8.630748
 Tel: 228 305 348/422 | Tlm: 964 096 068 | Fax: 228305425
 www.sertequi.pt | geral@sertequi.pt