

TIPO / TYPE

GTS – FILETTATO / SCREWED

GTF – FLANGIATO / FLANGED

DESCRIZIONE

Il GTS e il GTF sono scaricatori di condensa a galleggiante con corpo in ghisa sferoidale GGG 40.3 e dispositivo automatico di sfiato aria incorporato

(eliminatore d'aria). Disponibile nei diametri :

Ø 1/2" - Ø 3/4" - Ø 1"

DN 15 - DN 20 - DN 25

DESCRIPTION

GTS and GTF are SG iron GGG 40.3 ball float traps with integral automatic air venting facility.

Allowable in the following sizes :

Ø 1/2" - Ø 3/4" - Ø 1"

DN 15 - DN 20 - DN 25

DIAMETRI NOMINALI / NOMINAL SIZES

ATTACCHI CORPO / BODY CONNECTIONS

MATERIALE GRUPPO CORPO / BODY MATERIAL

MATERIALI INTERNI / INTERNAL MATERIALS

MAX PRESSIONE OPERATIVA (PMO) / MAX OPERATING PRESSURE (PMO)

MAX TEMP. OPERATIVA (TMO) / MAX OPERATING TEMP. (TMO)

MAX PRESSIONE AMMISSIBILE (PMA) / MAX ALLOWABLE PRESSURE (PMA)

MAX TEMP. AMMISSIBILE (TMA) / MAX ALLOWABLE TEMP. (TMA)

MAX PRESS. DIFFERENZIALE (PMD) / MAX DIFFERENTIAL PRESS.(PMD)

DIMENSIONI DI INGOMBRO IN mm E PESO / DIMENSIONS IN mm AND WEIGHT

Ø 1/2" - DN 15	Ø 3/4" - DN 20	Ø 1" - DN 25
Filettati BSP (Rp ISO 7) / BSP screwed (Rp ISO 7)		
Flangiati DIN 2533 PN 16 / DIN 2533 Flanged PN 16		
GHISA SFEROIDALE GGG40.3 / SG IRON GGG40.3		
ACCIAIO INOX AISI 304 / STAINLESS STEEL AISI 304		
(Limite Flange)	16 bar	(Connections limit)
250 °C		
25 bar		
300 °C		
4,5 bar	10 bar	14 bar

Ø	DN	A	K	B	C	D	Peso/Weight (Kg)	
							Screwed	Flanged
1/2"	15	150	150	108	68	122	3.2	4
3/4"	20	150	150	108	68	122	3.2	4.8
1"	25	180	167	108	107	145	4.7	7.1

GTS
Versione Filettato /
Screwed Version

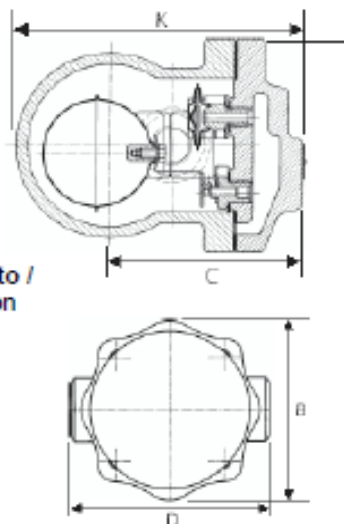

GTF
Versione Flangiato /
Flanged Version

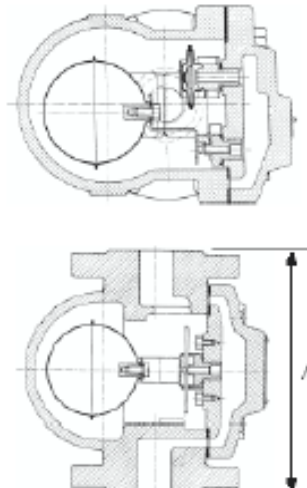

GTS / GTF – CAPACITA' DI SCARICO / DISCHARGE CAPACITIES

GRAFICO "A" "A" CHART Δp Press. Differenziale / Δp Diff. Press.	GRAFICO "B" "B" CHART Δp Press. Differenziale / Δp Diff. Press.	GRAFICO "C" "C" CHART Δp Press. Differenziale / Δp Diff. Press.
14	10	4.5

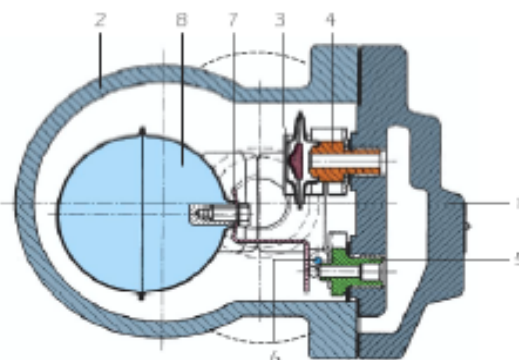
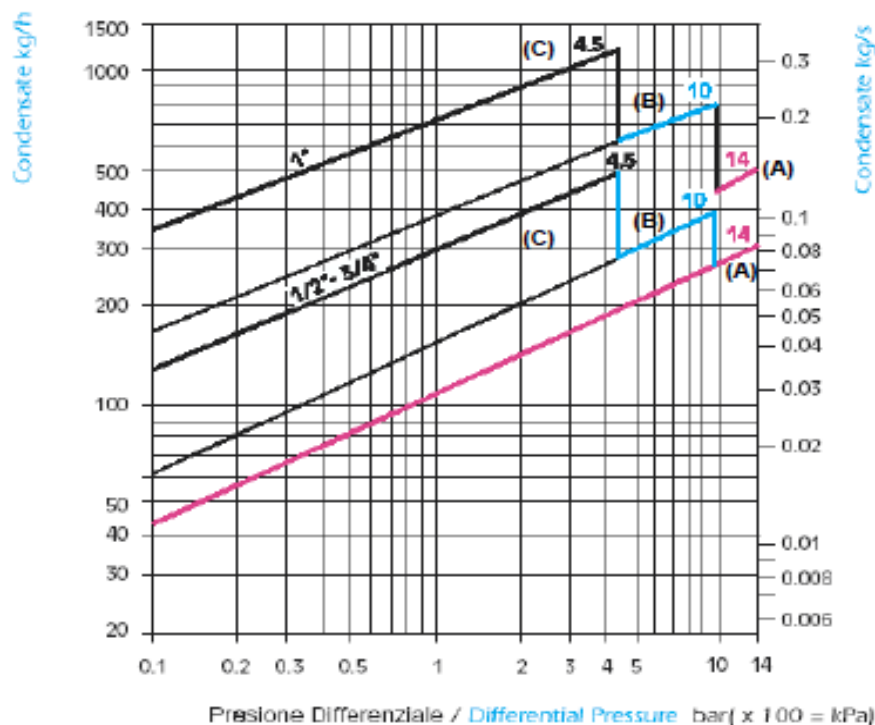

RICAMBI / SPARE PARTS		
1	CORPO / Body	GGG 40.3
2	COPERCHIO / Cover	GGG 40.3
3	CAPSULA TERMOSTATICA / Thermostatic Capsule	ACCIAIO INOX / Stainless Steel
4	ELIMINATORE D'ARIA / Air Vent Seat	ACCIAIO INOX AISI 304 / Stainless Steel AISI 304
5	SEDE / Float Seat	ACCIAIO INOX AISI 304 / Stainless Steel AISI 304
6	VALVOLA / Main Valve (ball)	ACCIAIO INOX / Stainless Steel
7	LEVA GALLEGGIANTE / Float Lever	ACCIAIO INOX AISI 304 / Stainless Steel AISI 304
8	GALLEGGIANTE / Float	ACCIAIO INOX AISI 304 / Stainless Steel AISI 304

I dati tecnici forniti hanno solo valore indicativo e non sono impegnativi per il costruttore che si riserva la facoltà di cambiarli in qualsiasi momento senza obbligo di preavviso.

Specifications given are only indicative and not binding for the manufacturer who reserve the right to carry-out any modifications deemed necessary without prior notice.