

THREE-WAY MIXING CONTROL VALVES

PED 97/23/CE / ATEX 94/9/CE / MACHINERY DIRECTIVE 2006/42/CE

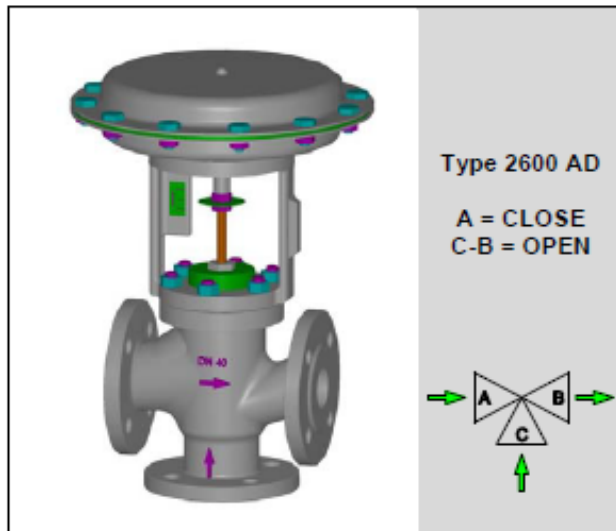

SIZES : from DN 15 to DN 100

BODY CONNECTIONS : flanged EN 1092-1 PN16 PN40

MATERIALS OF BODY GROUP (1) :

- Cast iron EN-GJL-250 UNI EN 1561 PN 16
AISI 316 st. st. trim - C40 nickel plated steel bonnet
- SG Iron DIN 1693 EN-GJS400-18LT (GGG 40.3)
AISI 316 st. st. trim - C40 nickel plated steel bonnet
- Carbon steel 1.0619 PN 16 ... PN 40
AISI 316 st. st. trim - C40 nickel plated steel bonnet
- Stainless steel AISI 316 1.4408 PN 16 ... PN 40
AISI 316 st. st. trim - AISI 316 st. st. bonnet

PLUG :

- PL (DN15-20) LV (DN25-100) = linear class IV*
- PT (DN15-20) VPT (DN25-100) = quick lift class IV*

BONNET (2) :

- Standard : -5 to +200 °C
- Finned : > 200 °C
- Extended : below -5 °C
- Bellows sealed : for thermal oil or hazardous media with standard safety gland arrangement (PN 16 - 25 - 40)

GLAND ARRANGEMENT (PACKING) (3) with safety "O-rings" :

- PTFE 100% for temperatures ≤ 150 °C
- PTFE 85% + GRAPHITE 15% for temperatures ≤ 200 °C
- PURE GRAPHITE 100% for temperatures from 200° to 400 °C to be used with finned bonnet

CV = american unit (flowrate in USGPM with 1 psi of differential pressure)

TYPE 2600 AD

Normally closed port "A" on air failure

Face-to-face EN 558-1

DESCRIPTION

The "UNIWORLD" series type 2600 AD are equipped with EN "straight-through" pattern bodies with EN flanges.

Type 2600 AD three-way mixing control valves (two inlet ports and one outlet port with fluid opens) have a modulating plug suitable for control of virtually all line media.

Compact construction assembled with multisprings pneumatic actuator having 3-15 psi ... 6-18 psi ... 6-30 psi standard control signals

On request can be equipped with a pneumatic or electro-pneumatic pilot positioner.

TECHNICAL CHARACTERISTICS OF PNEUMATIC ACTUATOR :

- Actuator : diaphragm type
- Control signals : 3-15 psi ... 6-18 psi ... 6-30 psi
- Max air supply pressure : 35 psi (2,5 bar)
- Ambient temperature : -20 ... +70 °C *see on request
- Actuator casings material : Fe P11 carbon steel
- Diaphragm material : EPDM 70
- Yoke material : EN-GJS500-7 spheroidal cast iron
- Pneumatic connections : ISO 7 Rp - 1/8"

MAX WORKING CONDITIONS :

- Max inlet pressure and temperature : see leaflet n° 101/VP
- Valve sizing : see leaflet n° 100/VP
- Rangeability : see leaflet n° GRAFIC/I/I

ON REQUEST :

- PTFE/GR soft seal ≤ 190 °C class VI*
- PTFE soft seal ≤ 150 °C class VI*
- Lapping on seat and plug class V*
- Stellite (degree 6°) on seat and plug and guide bush
- Reduced bore (see below table)
- Pneumatic pilot positioner 3-15 psi...3-9 psi...9-15 psi
- Electro-pneumatic pilot positioner 4-20 mA...4-12 mA...12-20 mA
- Air filter regulator
- Proximity limit switches
- 3-way solenoid valve
- Lubricator on finned bonnet for temperatures ≥ 250 °C
- Top-work manual handwheel
- ATEX 94/9/CE dedicated configuration according to the fluid
- Kit diaphragm and actuator seals certified for a.t. ≥ -50 °C

Kv = metric unit (flowrate in m3/h with 1 bar of differential pressure)

Plug	Full bore	DN 15	DN 20	DN 25	DN 32	DN 40	DN 50	DN 65	DN 80	DN 100
		Ø 1/2"	Ø 3/4"	Ø 1"	Ø 1.1/4"	Ø 1.1/2"	Ø 2"	Ø 2.1/2"	Ø 3"	Ø 4"
PL	CV	3.4	6.6	10	23.4	28	36.4	72.7	89.3	123.8
	KV	2.9	5.7	8.6	20.1	24.1	31.4	62.7	77	106.7
PT	CV	3.4	6.6	13.8	30.3	38.7	52	99.6	116.2	162.4
	KV	2.9	5.7	11.9	26.1	33.4	44.8	85.8	100.1	140
Reduced bore*		n.a.	1/2"	1/2" 3/4"	3/4" 1"	1" 1.1/4"	1.1/4" 1.1/2"	1.1/2" 2"	2" 2.1/2"	2.1/2" 3"

n.a. = not applicable

* CV and KV values are referred to the selected diameter and plug type (PL/LV only)

**Maximum permissible pressure drops in Kg/cm² (fluid opens)
Strokes in mm – Signals in psi**

Actuator type	Signal psi	DN 15	DN 20	DN 25	DN 32	DN 40	DN 50	DN 65	DN 80	DN 100
		stroke 11	stroke 11	stroke 11	stroke 19	stroke 19	stroke 19	stroke 28	stroke 28	stroke 28
T200	3-15 psi	12	8	5	3	-	-	-	-	-
	6-18 psi	25	16	9	5.2	-	-	-	-	-
	6-30 psi	65	40	22	11	-	-	-	-	-
T250	3-15 psi	27	17	9	6	4	2.4	-	-	-
	6-18 psi	55	34	19	12	8	3	-	-	-
	6-30 psi	110	68	38	20	14.5	7	-	-	-
T310	3-15 psi	-	-	15.5	10	7	3.5	2.5	1.7	0.9
	6-18 psi	-	-	31	20	14	7	4.2	2.8	1.3
	6-30 psi	-	-	62	30	21	12	6.5	4.7	2.6
T400	3-15 psi	-	-	-	14.5	10.5	5	3.8	2.5	1.4
	6-18 psi	-	-	-	29.5	20.5	12	6.7	4	2.8
	6-30 psi	-	-	-	45	31.5	18	16	11	6.3
T500	3-15 psi	-	-	-	24.5	17.5	9.5	5.5	4.2	2.4
	6-18 psi	-	-	-	49	34.5	19.5	12.2	7	4.9
	6-30 psi	-	-	-	75	52.5	30.3	26	16	10.5

1. The values given are referred to the force of actuator and they can be used within the limit of the body rating
2. The actuator DELTA-PI (PRESSURE DROPS with CLOSED VALVE) are obtained without a residual thrust of air into the actuator
3. The actuator DELTA-PI given in the column 6-30 psi are also valid for ON-OFF service with air supply at 30/35 psi

COMPONENTS LIST AND MATERIALS

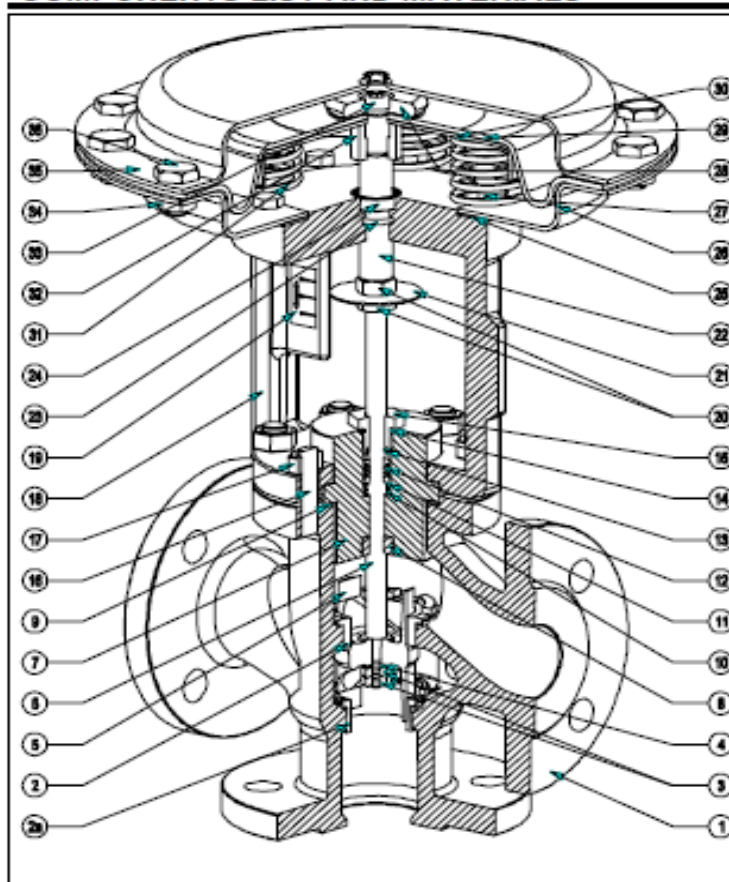

COMPONENTS LIST	MATERIALS
1. Body	1. See note (1) at page 1
2. Upper seat	2. AISI 316 stainless steel
2a. Lower seat	2a. AISI 316 stainless steel
3. Plug locknuts	3. AISI 304 stainless steel
4. Spring washer	4. AISI 304 stainless steel
5. Plug	5. AISI 316 stainless steel
6. Stem	6. AISI 316 stainless steel
7. Bonnet	7. See notes (1)-(2) at page 1
8. Guide bush	8. AISI 304 stainless steel
9. Body gasket	9. Europil WS 3640 or PTFE
10. Packing spring	10. AISI 302 stainless steel
11. Packing washer	11. AISI 304 stainless steel
12. Packing rings	12. See note (3) at page 1
13. Internal "O" ring	13. Viton FPM 70
14. External "O" ring	14. Viton FPM 70
15. Packing adjusting nut	15. AISI 303 stainless steel
16. Stud-bolts	16. Galvanized steel
17. Body locknuts	17. DIN 934 galvanized steel
18. Yoke	18. GGG50 spheroidal c. iron
19. Travel indicator plate	19. Polycarbonate
20. Position indicator locknuts	20. DIN 936 galvanized steel
21. Position indicator	21. Aluminium
22. Diaphragm rod	22. AISI 303 stainless steel
23. "O" ring	23. NBR
24. Airtight	24. NBR
25. Yoke gasket	25. Cork – rubber
26. Lower diaphragm casing	26. P11 steel
27. Lower diaphragm casing internal bolts	27. DIN 933 galvanized steel
28. Diaphragm spacer	28. Galvanized steel
29. Diaphragm	29. EPDM 70
30. Diaphragm plate	30. P01 steel
31. Springs	31. C98 UNI 3823
32. Diaphragm bush	32. AISI 303 stainless steel
33. Diaphragm locknut	33. ISO 7380 galvanized steel
34. Diaphragm casing bolts	34. DIN 934 galvanized steel
35. Upper diaphragm casing	35. P11 steel
36. Diaphragm casing locknuts	36. DIN 933 galvanized steel

DIMENSIONS in mm.

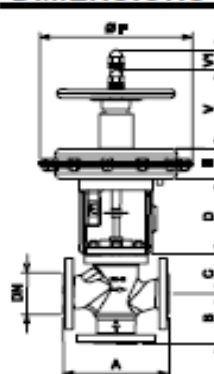

DN	Ø	A	B	C - Bonnet			D	V	V1	Actuator	E	Ø F
				Std	Finned	Bellows						
15	1/2"	130	70	49	181	181	147	166	11	T200	70	210
20	3/4"	150	80	58	190	190	147	166	11	T250	70	292
25	1"	160	85	68	200	200	147	166	11	T310	95	336
32	1.1/4"	180	100	70	202	202	147	166	19	T400	119	408
40	1.1/2"	200	105	82	214	214	160	166	19	T500	119	520
50	2"	230	120	86	218	218	160	166	19			
65	2.1/2"	290	130	111	309	309	160	166	28			
80	3"	310	140	135	333	333	160	166	28			
100	4"	350	150	160	363	363	204	166	28			

Specifications given are only indicative and not binding for the manufacturer who reserve the right to carry-out any modifications deemed necessary without prior notice. All data sheets by CONFLOW SpA, are available last update on our Internet web site www.conflow.it.

THREE-WAY MIXING CONTROL VALVES CE

PED 97/23/CE / ATEX 94/9/CE / MACHINERY DIRECTIVE 2006/42/CE

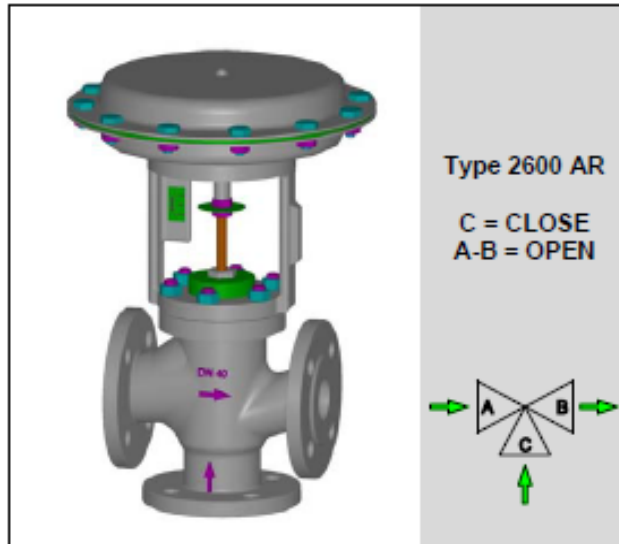

Type 2600 AR

C = CLOSE
A-B = OPEN

TYPE 2600 AR

Normally closed port "C" on air failure

Face-to-face EN 558-1

DESCRIPTION

The "UNIWORLD" series type 2600 AR are equipped with EN "straight-through" pattern bodies with EN flanges.

Type 2600 AR three-way mixing control valves (two inlet ports and one outlet port with fluid opens) have a modulating plug suitable for control of virtually all line media.

Compact construction assembled with multisprings pneumatic actuator having 3-15 psi ... 6-18 psi ... 6-30 psi standard control signals

On request can be equipped with a pneumatic or electro-pneumatic pilot positioner.

SIZES : from DN 15 to DN 100

BODY CONNECTIONS : flanged EN 1092-1 PN16 PN40

MATERIALS OF BODY GROUP (1) :

- Cast iron EN-GJL-250 UNI EN 1561 PN 16
AISI 316 st. st. trim - C40 nickel plated steel bonnet
- SG iron DIN 1693 EN-GJS400-18LT (GGG40.3)
AISI 316 st. st. trim - C40 nickel plated steel bonnet
- Carbon steel 1.0619 PN 16 ... PN 40
AISI 316 st. st. trim - C40 nickel plated steel bonnet
- Stainless steel AISI 316 1.4408 PN 16 ... PN 40
AISI 316 st. st. trim - AISI 316 st. st. bonnet

PLUG :

- PL (DN15-20) LV (DN25-100) = linear class IV*
- PT (DN15-20) VPT (DN25-100) = quick lift class IV*

BONNET (2) :

- Standard : -5 to +200 °C
- Finned : > 200 °C
- Extended : below -5 °C
- Bellows sealed : for thermal oil or hazardous media with standard safety gland arrangement (PN 16 - 25 - 40)

GLAND ARRANGEMENT (PACKING) (3) with safety "O-rings" :

- PTFE 100% for temperatures ≤150 °C
- PTFE 85% + GRAPHITE 15% for temperatures ≤ 200 °C
- PURE GRAPHITE 100% for temperatures from 200° to 400 °C to be used with finned bonnet

CV = american unit (flowrate in USGPM with 1 psi of differential pressure)

TECHNICAL CHARACTERISTICS OF PNEUMATIC ACTUATOR :

- Actuator : diaphragm type
- Control signals : 3-15 psi ... 6-18 psi ... 6-30 psi
- Max air supply pressure : 35 psi (2,5 bar)
- Ambient temperature : -20 ... +70 °C *see on request
- Actuator casings material : Fe P11 carbon steel
- Diaphragm material : EPDM 70
- Yoke material : EN-GJS500-7 spheroidal cast iron
- Pneumatic connections : ISO 7 Rp - 1/8"

MAX WORKING CONDITIONS :

- Max inlet pressure and temperature : see leaflet n° 101/VP
- Valve sizing : see leaflet n° 100/VP
- Rangeability : see leaflet n° GRAFICI/I

ON REQUEST :

- PTFE/GR soft seal ≤190°C class VI*
- PTFE soft seal ≤150°C class VI*
- Lapping on seat and plug class V*
- Stellite (degree 6°) on seat and plug and guide bush
- Reduced bore (see below table)
- Pneumatic pilot positioner 3-15 psi...3-9 psi...9-15 psi
- Electro-pneumatic pilot positioner 4-20 mA...4-12 mA...12-20 mA
- Air filter regulator
- Proximity limit switches
- 3-way solenoid valve
- Lubrifier on finned bonnet for temperatures ≥ 250 °C
- Top-work manual handwheel
- ATEX 94/9/CE dedicated configuration according to the fluid
- Kit diaphragm and actuator seals certified for a.t. ≥ - 50 °C

Kv = metric unit (flowrate in m3/h with 1 bar of differential pressure)

Plug		DN 15	DN 20	DN 25	DN 32	DN 40	DN 50	DN 65	DN 80	DN 100							
Full bore		Ø 1/2"	Ø 3/4"	Ø 1"	Ø 1.1/4"	Ø 1.1/2"	Ø 2"	Ø 2.1/2"	Ø 3"	Ø 4"							
PL	CV	3.4	6.6	10	23.4	28	36.4	72.7	89.3	123.8							
	KV	2.9	5.7	8.6	20.1	24.1	31.4	62.7	77	106.7							
PT	CV	3.4	6.6	13.8	30.3	38.7	52	99.6	116.2	162.4							
	KV	2.9	5.7	11.9	26.1	33.4	44.8	85.8	100.1	140							
Reduced bore*		n.a.	1/2"	1/2"	3/4"	3/4"	1"	1"	1.1/4"	1.1/4"	1.1/2"	1.1/2"	2"	2"	2.1/2"	2.1/2"	3"

n.a. = not applicable

* CV and KV values are referred to the selected diameter and plug type (PL/LV only)

**Maximum permissible pressure drops in Kg/cm² (fluid opens)
Strokes in mm – Signals in psi**

Actuator type	Signal psi	DN 15	DN 20	DN 25	DN 32	DN 40	DN 50	DN 65	DN 80	DN 100
		stroke 11	stroke 11	stroke 11	stroke 19	stroke 19	stroke 19	stroke 28	stroke 28	stroke 28
T200	3-15 psi	12	8	5	3	-	-	-	-	-
	6-18 psi	25	16	9	5,2	-	-	-	-	-
	6-30 psi	65	40	22	11	-	-	-	-	-
T250	3-15 psi	27	17	9	6	4	2,4	-	-	-
	6-18 psi	55	34	19	12	8	3	-	-	-
	6-30 psi	110	68	38	20	14,5	7	-	-	-
T310	3-15 psi	-	-	15,5	10	7	3,5	2,5	1,7	0,9
	6-18 psi	-	-	31	20	14	7	4,2	2,8	1,3
	6-30 psi	-	-	62	30	21	12	6,5	4,7	2,6
T400	3-15 psi	-	-	-	14,5	10,5	5	3,8	2,5	1,4
	6-18 psi	-	-	-	29,5	20,5	12	6,7	4	2,8
	6-30 psi	-	-	-	45	31,5	18	16	11	6,3
T500	3-15 psi	-	-	-	24,5	17,5	9,5	5,5	4,2	2,4
	6-18 psi	-	-	-	49	34,5	19,5	12,2	7	4,9
	6-30 psi	-	-	-	75	52,5	30,3	26	16	10,5

1. The values given are referred to the force of actuator and they can be used within the limit of the body rating
2. The actuator DELTA-PI (PRESSURE DROPS with CLOSED VALVE) are obtained without a residual thrust of air into the actuator
3. The actuator DELTA-PI given in the column 6-30 psi are also valid for ON-OFF service with air supply at 30/35 psi

COMPONENTS LIST AND MATERIALS

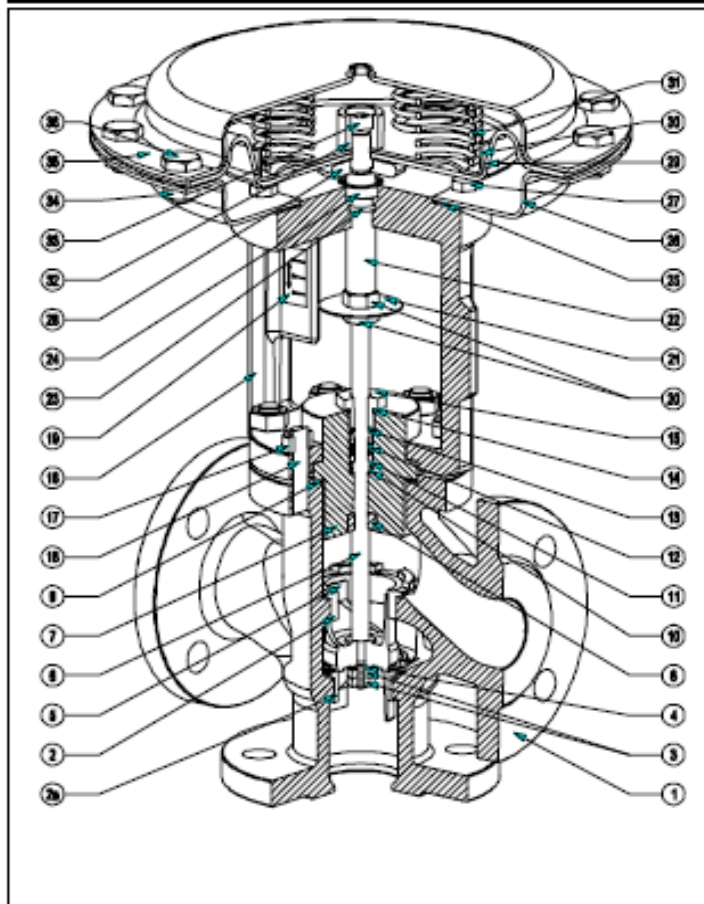

COMPONENTS LIST

1. Body
2. Upper seat
- 2a. Lower seat
3. Plug locknuts
4. Spring washer
5. Plug
6. Stem
7. Bonnet
8. Guide bush
9. Body gasket
10. Packing spring
11. Packing washer
12. Packing rings
13. Internal "O" ring
14. External "O" ring
15. Packing adjusting nut
16. Stud-bolts
17. Body locknuts
18. Yoke
19. Travel indicator plate
20. Position indicator locknuts
21. Position indicator
22. Diaphragm rod
23. "O" ring
24. Airtight
25. Yoke gasket
26. Lower diaphragm casing
27. Lower diaphragm casing internal bolts
28. Diaphragm spacer
29. Diaphragm
30. Diaphragm plate
31. Springs
32. Diaphragm bush
33. Diaphragm locknut
34. Diaphragm casing bolts
35. Upper diaphragm casing
36. Diaphragm casing locknuts

MATERIALS

1. See note (1) at page 1
2. AISI 316 stainless steel
- 2a. AISI 316 stainless steel
3. AISI 304 stainless steel
4. AISI 304 stainless steel
5. AISI 316 stainless steel
6. AISI 316 stainless steel
7. See notes (1)-(2) at page 1
8. AISI 304 stainless steel
9. Europil WS 3640 or PTFE
10. AISI 302 stainless steel
11. AISI 304 stainless steel
12. See note (3) at page 1
13. Viton FPM 70
14. Viton FPM 70
15. AISI 303 stainless steel
16. Galvanized steel
17. DIN 934 galvanized steel
18. GGG50 spheroidal c. iron
19. Polycarbonate
20. DIN 936 galvanized steel
21. Aluminium
22. AISI 303 stainless steel
23. NBR
24. NBR
25. Cork – rubber
26. P11 steel
27. DIN 933 galvanized steel
28. Galvanized steel
29. EPDM 70
30. P01 steel
31. C98 UNI 3823
32. AISI 303 stainless steel
33. ISO 7380 galvanized steel
34. DIN 934 galvanized steel
35. P11 steel
36. DIN 933 galvanized steel locknuts

DIMENSIONS in mm.

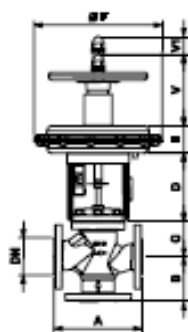

DN	Ø	A	B	C - Bonnet			D	V	V1
				Std	Finned	Bellows			
15	1/2"	130	70	49	181	181	147	166	11
20	3/4"	150	80	58	190	190	147	166	11
25	1"	160	85	68	200	200	147	166	11
32	1.1/4"	180	100	70	202	202	147	166	19
40	1.1/2"	200	105	82	214	214	160	166	19
50	2"	230	120	86	218	218	160	166	19
65	2.1/2"	290	130	111	309	309	160	166	28
80	3"	310	140	135	333	333	160	166	28
100	4"	350	150	160	363	363	204	166	28

Actuator	E	Ø F
T200	70	210
T250	70	292
T310	95	336
T400	119	408
T500	119	520

Specifications given are only indicative and not binding for the manufacturer who reserve the right to carry-out any modifications deemed necessary without prior notice. All data sheets by CONFLOW SpA, are available last update on our Internet web site www.conflow.it.