

SINGLE SEAT TWO WAY CONTROL VALVES **CE**
PED 97/23/CE / ATEX 94/9/CE / MACHINERY DIRECTIVE 2006/42/CE

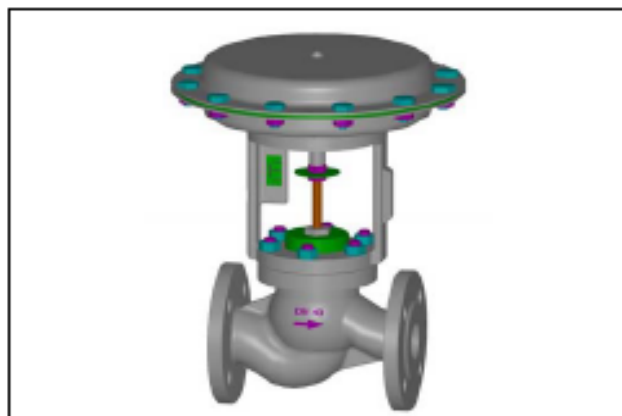

TYPE 2000 AD

Normally open – air closes

Face-to-face EN 558-1

DESCRIPTION

The "UNIWORLD" series type 2000 AD are equipped with EN "straight-through" pattern bodies with EN flanges. Modulating plug suitable for control of virtually all line media. Compact construction assembled with multisprings pneumatic actuator having 3-15 psi ...6-30 psi standard control signals. On request can be equipped with a pneumatic or electro-pneumatic pilot positioner.

SIZES : from DN 15 to DN 100

BODY CONNECTIONS : flanged EN 1092-1 PN16 PN40

MATERIALS OF BODY GROUP (1) :

- Cast Iron EN-GJL-250 UNI EN 1561 PN 16
AISI 316 st. st. trim - C40 nickel plated steel bonnet
- Carbon steel 1.0619 PN 16 ... PN 40
AISI 316 st. st. trim - C40 nickel plated steel bonnet
- Stainless steel AISI 316 1.4408 PN 16 ... PN 40
AISI 316 st. st. trim – AISI 316 st. st. bonnet

PLUG :

- EQP (DN15-50) EQV (DN65-100) = equal percentage class IV*
- PL (DN15-50) LV (DN65-100) = linear class IV*
- PT (DN15-50) VPT (DN65-100) = quick lift class IV*

BONNET (2) :

- Standard : -5 to +200 °C
- Finned : > 200 °C
- Extended : below -5 °C
- Bellows sealed : for thermal oil or hazardous media with standard safety gland arrangement (PN 16 - 25 - 40)

GLAND ARRANGEMENT (PACKING) (3) with safety "O-rings" :

- PTFE 100% for temperatures ≤150 °C
- PTFE 85% + GRAPHITE 15% for temperatures ≤ 200 °C
- PURE GRAPHITE 100% for temperatures from 200° to 400 °C to be used with finned bonnet

CV = american unit (flowrate in USGPM with 1 psi of differential pressure)

TECHNICAL CHARACTERISTICS OF PNEUMATIC ACTUATOR :

- Actuator : diaphragm type
- Control signals : 3-15 psi ...6-30 psi
- Max air supply pressure : 35 psi (2,5 bar)
- Ambient temperature : -20 ... +70 °C *see on request
- Actuator casings material : Fe P11 carbon steel
- Diaphragm material : EPDM 70
- Yoke material : EN-GJS500-7 spheroidal cast Iron
- Pneumatic connections : ISO 7 Rp – 1/8"

MAX WORKING CONDITIONS :

- Max inlet pressure and temperature : see leaflet n° 101/VP
- Valve sizing : see leaflet n° 100/VP
- Rangeability : see leaflet n° GRAFIC/II

ON REQUEST :

- PTFE/GR soft seal ≤190°C class VI*
- PTFE soft seal ≤150°C class VI*
- Lapping on seat and plug class V*
- Stellite (degree 6") on seat and plug and guide bush
- Reduced bore (see below table)
- Pneumatic pilot positioner 3-15 psi...3-9 psi...9-15 psi
- Electro-pneumatic pilot positioner 4-20 mA...4-12 mA...12-20 mA
- Air filter regulator
- Proximity limit switches
- 3-way solenoid valve
- Lubrifier on finned bonnet for temperatures ≥ 250 °C
- Top-work manual handwheel
- ATEX 94/9/CE dedicated configuration according to the fluid
- Kit diaphragm and actuator seals certified for a.t. ≥ - 50 °C

Kv = metric unit (flowrate in m3/h with 1 bar of differential pressure)

PLUG		DN 15	DN 20	DN 25	DN 32	DN 40	DN 50	DN 65	DN 80	DN 100									
Full bore		Ø 1/2"	Ø 3/4"	Ø 1"	Ø 1.1/4"	Ø 1.1/2"	Ø 2"	Ø 2.1/2"	Ø 3"	Ø 4"									
EQP	CV	3.4	6.6	10.8	17	23.8	50	70.2	87.9	118.5									
	KV	2.9	5.7	9.3	14.7	20.5	43	60.5	75.2	102.1									
PL	CV	3.4	6.6	11.2	17.6	23.9	51.2	72.7	89.3	123.8									
	KV	2.9	5.7	9.6	15.2	20.6	44	62.7	77	106.7									
PT	CV	3.4	6.6	12.1	19	24	52.7	107.3	129.3	175.4									
	KV	2.9	5.7	10.4	16.4	20.7	45.3	92.5	111.5	151.2									
Reduced bore *		•	•	1/2"	1/2"	3/4"	3/4"	1"	1"	1.1/4"	1.1/4"	1.1/2"	1.1/2"	2"	2"	2.1/2"	2.1/2"	3"	
• DN 15-20		MFP 1/8"	MFP 3/16"	MFP 1/4"	MFP 3/8"	MFS1S/G 1/4"	MFS2S/G 1/4"	MFS1S/G 3/8"	MFS2S/G 3/8"										
		CV	0.26	0.71	1.28	2.62	0.65	1.21	1.22	2.25									
		KV	0.22	0.61	1.10	2.26	0.56	1.04	1.05	1.94									

MFP = Linear..MFS = Equal percentage * CV and KV values are referred to the selected diameter and plug type (EQP/EQV-PL/LV only)

Maximum permissible pressure drops in Kg/cm2 (fluid opens)

Strokes in mm – Signals in psi

Actuator type	Signal psi	DN 15	DN 20	DN 25	DN 32	DN 40	DN 50	DN 65	DN 80	DN 100
		stroke 11	stroke 11	stroke 11	stroke 19	stroke 19	stroke 19	stroke 28	stroke 28	stroke 28
T200	3-15 psi	12	8	5	3	-	-	-	-	-
	6-30 psi	52	32	18	11	-	-	-	-	-
T250	3-15 psi	27	17	9	6	4	2.4	-	-	-
	6-30 psi	113	69	39	25	17	10	-	-	-
T310	3-15 psi	-	-	15.5	10	7	3.5	2.5	1.7	0.9
	6-30 psi	-	-	63	41	28	16	10	7	4
T400	3-15 psi	-	-	-	14.5	10.5	5.5	3.8	2.5	1.4
	6-30 psi	-	-	-	60	42	24	15	10.5	5.9
T500	3-15 psi	-	-	-	24.5	17.5	9.5	6.2	4.2	2.4
	6-30 psi	-	-	-	101	70	40	25.3	17.5	9.9
T200 DN15-20 Microflow	Signal	MFP 1/8"	MFP 3/16"	MFP 1/4"	MFP 3/8"	MFS18G 1/4"	MFS28G 1/4"	MFS18G 3/8"	MFS28G 3/8"	
	3-15 psi	200	90	50	30	50	50	30	30	
	6-30 psi	1080	470	270	130	270	270	130	130	

1. The values given are referred to the force of actuator and they can be used within the limit of the body rating
2. The actuator DELTA-PI (PRESSURE DROPS with CLOSED VALVE) given in the column 3-15 psi are obtained with a thrust of 18 psi
3. The actuator DELTA-PI (PRESSURE DROPS with CLOSED VALVE) given in the column 6-30 psi are obtained with a thrust of 30 psi
4. The actuator DELTA-PI given in the column 6-30 psi are also valid for ON-OFF service with air supply at 30/35 psi

COMPONENTS LIST AND MATERIALS

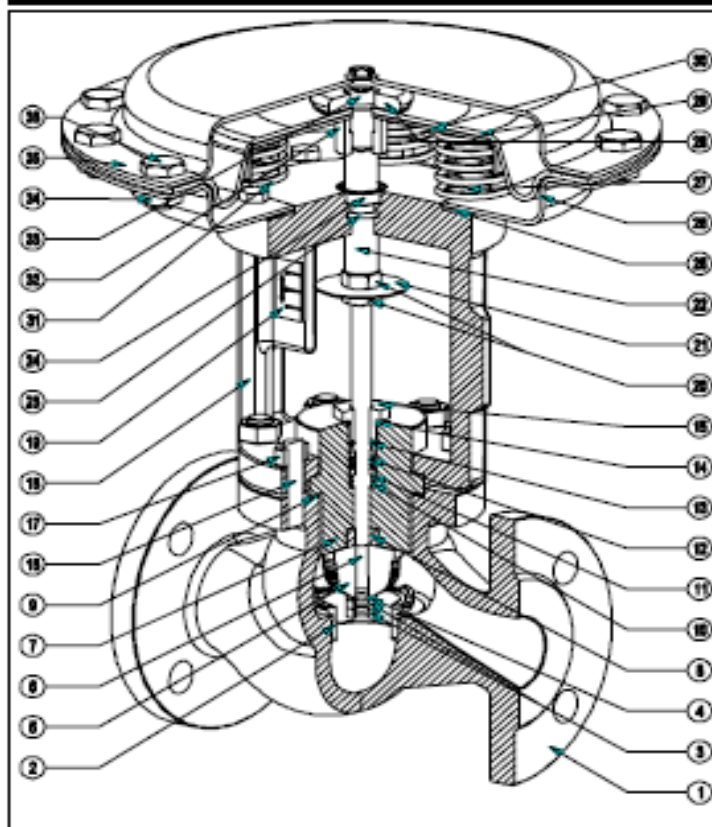

COMPONENTS LIST	MATERIALS
1. Body	1. See note (1) at page 1
2. Seat	2. AISI 316 stainless steel
3. Plug locknuts	3. AISI 304 stainless steel
4. Spring washer	4. AISI 304 stainless steel
5. Plug	5. AISI 316 stainless steel
6. Stem	6. AISI 316 stainless steel
7. Bonnet	7. See notes (1)-(2) at page 1
8. Guide bush	8. AISI 304 stainless steel
9. Body gasket	9. Europl WS 3640 or PTFE
10. Packing spring	10. AISI 302 stainless steel
11. Packing washer	11. AISI 304 stainless steel
12. Packing rings	12. See note (3) at page 1
13. Internal "O" ring	13. Viton FPM 70
14. External "O" ring	14. Viton FPM 70
15. Packing adjusting nut	15. AISI 303 stainless steel
16. Stud-bolts	16. Galvanized steel
17. Body locknuts	17. DIN 934 galvanized steel
18. Yoke	18. GG50 spheroidal c. Iron
19. Travel indicator plate	19. Polycarbonate
20. Position indicator locknuts	20. DIN 936 galvanized steel
21. Position indicator	21. Aluminium
22. Diaphragm rod	22. AISI 303 stainless steel
23. "O" ring	23. NBR
24. Airtight	24. NBR
25. Yoke gasket	25. Cork - rubber
26. Lower diaphragm casing	26. P11 steel
27. Lower diaphragm casing internal bolts	27. DIN 933 galvanized steel
28. Diaphragm spacer	28. Galvanized steel
29. Diaphragm	29. EPDM 70
30. Diaphragm plate	30. P01 steel
31. Springs	31. C98 UNI 3823
32. Diaphragm bush	32. AISI 303 stainless steel
33. Diaphragm locknut	33. ISO 7380 galvanized steel
34. Diaphragm casing bolts	34. DIN 934 galvanized steel
35. Upper diaphragm casing	35. P11 steel
36. Diaphragm casing locknuts	36. DIN 933 galvanized steel

DIMENSIONS in mm.

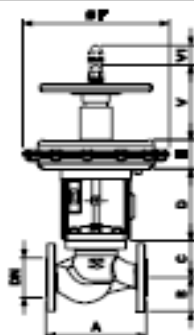

DN	Ø	A	B	C - Bonnet			D	V	V1
				Std	Finned	Bellows			
15	1/2"	130	47.5	49	181	181	147	166	11
20	3/4"	150	52.5	58	190	190	147	166	11
25	1"	160	57.5	68	200	200	147	166	11
32	1.1/4"	180	70	70	202	202	147	166	19
40	1.1/2"	200	75	82	214	214	160	166	19
50	2"	230	82.5	86	218	218	160	166	19
65	2.1/2"	290	92.5	111	309	309	160	166	28
80	3"	310	100	135	333	333	160	166	28
100	4"	350	118	160	363	363	204	166	28

Actuator	E	Ø F
T200	70	210
T250	70	292
T310	95	336
T400	119	408
T500	119	520

Specifications given are only indicative and not binding for the manufacturer who reserve the right to carry-out any modifications deemed necessary without prior notice. All data sheets by CONFLOW SpA, are available last update on our Internet web site

SINGLE SEAT TWO WAY CONTROL VALVES CE

PED 97/23/CE / ATEX 94/9/CE / MACHINERY DIRECTIVE 2006/42/CE

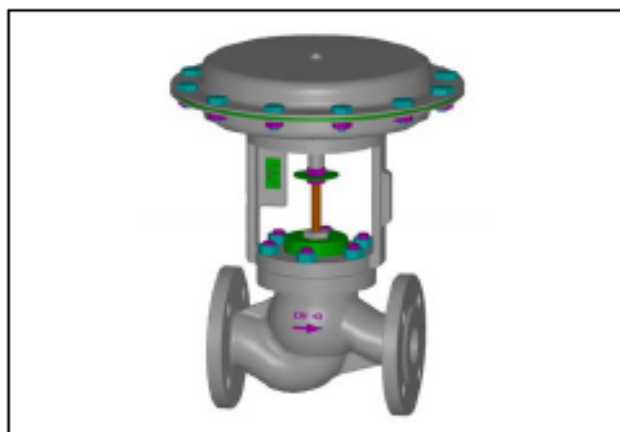

TYPE 2000 AR

Normally closed – air opens

Face-to-face EN 558-1

DESCRIPTION

The "UNIWORLD" series type 2000 AR are equipped with EN "straight-through" pattern bodies with EN flanges.

Modulating plug suitable for control of virtually all line media.

Compact construction assembled with multisprings pneumatic actuator having 3-15 psi ... 6.18 psi ... 6-30 psi standard control signals

On request can be equipped with a pneumatic or electro-pneumatic pilot positioner.

SIZES : from DN 15 to DN 100

BODY CONNECTIONS : flanged EN 1092-1 PN16 PN40

MATERIALS OF BODY GROUP (1) :

- Cast Iron EN-GJL-250 UNI EN 1561 PN 16
AISI 316 st. st. trim - C40 nickel plated steel bonnet
- Carbon steel 1.0619 PN 16 ... PN 40
AISI 316 st. st. trim - C40 nickel plated steel bonnet
- Stainless steel AISI 316 1.4408 PN 16 ... PN 40
AISI 316 st. st. trim - AISI 316 st. st. bonnet

PLUG :

- EQP (DN15-50) EQV (DN65-100) = equal percentage class IV*
- PL (DN15-50) LV (DN65-100) = linear class IV*
- PT (DN15-50) VPT (DN65-100) = quick lift class IV*

BONNET (2) :

- Standard : -5 to +200 °C
- Finned : > 200 °C
- Extended : below -5 °C
- Bellows sealed : for thermal oil or hazardous media with standard safety gland arrangement

GLAND ARRANGEMENT (PACKING) (3) with safety "O-rings" :

- PTFE 100% for temperatures ≤150 °C
- PTFE 85% + GRAPHITE 15% for temperatures ≤200 °C
- PURE GRAPHITE 100% for temperatures from 200° to 400 °C to be used with finned bonnet

CV = american unit (flowrate in USGPM with 1 psi of differential pressure)

PLUG	Full bore	DN 15	DN 20	DN 25	DN 32	DN 40	DN 50	DN 65	DN 80	DN 100									
		Ø 1/2"	Ø 3/4"	Ø 1"	Ø 1.1/4"	Ø 1.1/2"	Ø 2"	Ø 2.1/2"	Ø 3"	Ø 4"									
EQP	CV	3.4	6.6	10.8	17	23.8	50	70.2	87.9	118.5									
	KV	2.9	5.7	9.3	14.7	20.5	43	60.5	75.2	102.1									
PL	CV	3.4	6.6	11.2	17.6	23.9	51.2	72.7	89.3	123.8									
	KV	2.9	5.7	9.6	15.2	20.6	44	62.7	77	106.7									
PT	CV	3.4	6.6	12.1	19	24	52.7	107.3	129.3	175.4									
	KV	2.9	5.7	10.4	16.4	20.7	45.3	92.5	111.5	151.2									
Reduced bore *		•	•	1/2"	1/2"	3/4"	3/4"	1"	1"	1.1/4"	1.1/4"	1.1/2"	1.1/2"	1.1/2"	2"	2"	2.1/2"	2.1/2"	3"

• DN 15-20	MFP 1/8"	MFP 3/16"	MFP 1/4"	MFP 3/8"	MFS1SG 1/4"	MFS2SG 1/4"	MFS1SG 3/8"	MFS2SG 3/8"
CV	0.25	0.71	1.28	2.62	0.65	1.21	1.22	2.25
KV	0.22	0.61	1.10	2.26	0.56	1.04	1.05	1.94

MFP = Linear..MFS = Equal percentage * CV and KV values are referred to the selected diameter and plug type (EQP/EQV-PL/LV only)

TECHNICAL CHARACTERISTICS OF PNEUMATIC ACTUATOR :

- Actuator : diaphragm type
- Control signals : 3-15 psi ... 6-18 psi ... 6-30 psi
- Max air supply pressure : 35 psi (2,5 bar)
- Ambient temperature : -20 ... +70 °C *see on request
- Actuator casings material : Fe P11 carbon steel
- Diaphragm material : EPDM 70
- Yoke material : EN-GJS500-7 spheroidal cast Iron
- Pneumatic connections : ISO 7 Rp – 1/8"

MAX WORKING CONDITIONS :

- Max Inlet pressure and temperature : see leaflet n° 101/VP
- Valve sizing : see leaflet n° 100/VP
- Rangeability : see leaflet n° GRAFIC/I

ON REQUEST :

- PTFE/GR soft seal ≤190°C class VI*
- PTFE soft seal ≤150°C class VI*
- Lapping on seat and plug class V*
- Stellite (degree 6") on seat and plug and guide bush
- Reduced bore (see below table)
- Pneumatic pilot positioner 3-15 psi...3-9 psi...9-15 psi
- Electro-pneumatic pilot positioner 4-20 mA...4-12 mA...12-20 mA
- Air filter regulator
- Proximity limit switches
- 3-way solenoid valve
- Lubricator on finned bonnet for temperatures ≥ 250 °C
- Top-work manual handwheel
- ATEX 94/9/CE dedicated configuration according to the fluid
- Kit diaphragm and actuator seals certified for a.t. ≥ -50 °C

Kv = metric unit (flowrate in m3/h with 1 bar of differential pressure)

**Maximum permissible pressure drops in Kg/cm² (fluid opens)
Strokes in mm – Signals in psi**

Actuator type	Signal psi	DN 15	DN 20	DN 25	DN 32	DN 40	DN 50	DN 65	DN 80	DN 100
		stroke 11	stroke 11	stroke 11	stroke 19	stroke 19	stroke 19	stroke 28	stroke 28	stroke 28
T200	3-15 psi	12	8	5	3	-	-	-	-	-
	6-18 psi	25	16	9	5,2	-	-	-	-	-
	6-30 psi	65	40	22	11	-	-	-	-	-
T250	3-15 psi	27	17	9	6	4	2,4	-	-	-
	6-18 psi	55	34	19	12	8	3	-	-	-
	6-30 psi	110	68	38	20	14,5	7	-	-	-
T310	3-15 psi	-	-	15,5	10	7	3,5	2,5	1,7	0,9
	6-18 psi	-	-	31	20	14	7	4,2	2,8	1,3
	6-30 psi	-	-	62	30	21	12	6,5	4,7	2,6
T400	3-15 psi	-	-	-	14,5	10,5	5	3,8	2,5	1,4
	6-18 psi	-	-	-	29,5	20,5	12	6,7	4	2,8
	6-30 psi	-	-	-	45	31,5	18	16	11	6,3
T500	3-15 psi	-	-	-	24,5	17,5	9,5	5,5	4,2	2,4
	6-18 psi	-	-	-	49	34,5	19,5	12,2	7	4,9
	6-30 psi	-	-	-	75	52,5	30,3	26	16	10,5
T200 DN15-20 Microflow	Signal	MFP 1/8 *	MFP 3/16 *	MFP 1/4 *	MFP 3/8 *	MFS15G 1/4 *	MFS25G 1/4 *	MFS15G 3/8 *	MFS25G 3/8 *	
	3-15 psi	200	90	50	30	50	50	30	30	
	6-18 psi	400	180	100	60	100	100	60	60	
	6-30 psi	1300	580	340	160	340	340	160	160	

- The values given are referred to the force of actuator and they can be used within the limit of the body rating
- The actuator DELTA-PI (PRESSURE DROPS with CLOSED VALVE) are obtained without a residual thrust of air into the actuator
- The actuator DELTA-PI given in the column 6-30 psi are also valid for ON-OFF service with air supply at 30/35 psi

COMPONENTS LIST AND MATERIALS

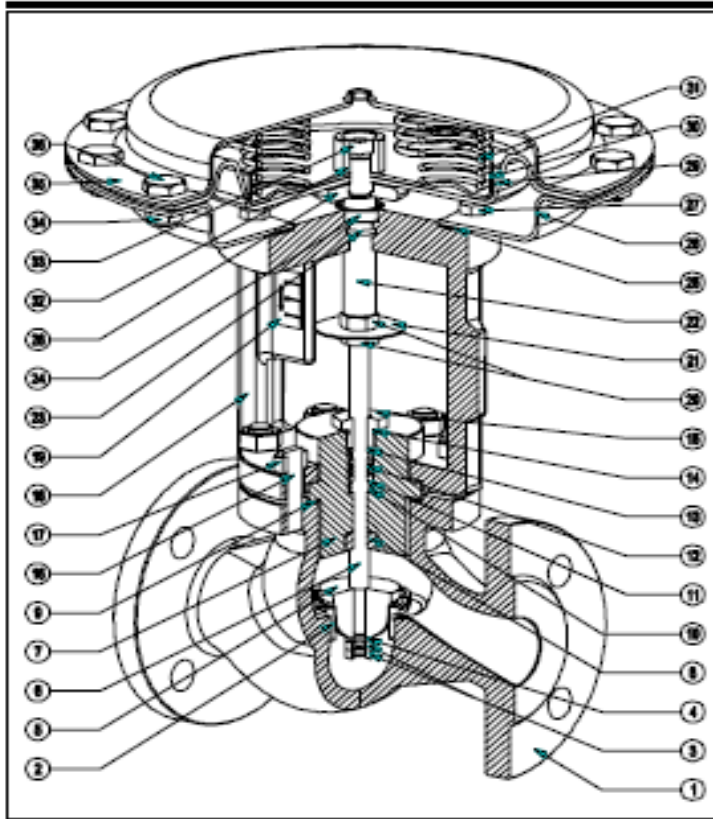

COMPONENTS LIST

- Body
- Seal
- Plug locknuts
- Spring washer
- Plug
- Stem
- Bonnet
- Guide bush
- Body gasket
- Packing spring
- Packing washer
- Packing rings
- Internal "O" ring
- External "O" ring
- Packing adjusting nut
- Stud-bolts
- Body locknuts
- Yoke
- Travel indicator plate
- Position indicator locknuts
- Position indicator
- Diaphragm rod
- "O" ring
- Airtight
- Yoke gasket
- Lower diaphragm casing
- Lower diaphragm casing internal bolts
- Diaphragm spacer
- Diaphragm
- Diaphragm plate
- Springs
- Diaphragm bush
- Diaphragm locknut
- Diaphragm casing bolts
- Upper diaphragm casing
- Diaphragm casing locknuts

MATERIALS

- See note (1) at page 1
- AISI 316 stainless steel
- AISI 304 stainless steel
- AISI 304 stainless steel
- AISI 316 stainless steel
- AISI 316 stainless steel
- See notes (1)-(2) at page 1
- AISI 304 stainless steel
- Europil WS 3640 or PTFE
- AISI 302 stainless steel
- AISI 304 stainless steel
- See note (3) at page 1
- Viton FPM 70
- Viton FPM 70
- AISI 303 stainless steel
- Galvanized steel
- DIN 934 galvanized steel
- GGG50 spheroidal c. Iron
- Polycarbonate
- DIN 936 galvanized steel
- Aluminium
- AISI 303 stainless steel
- NBR
- NBR
- Conk - rubber
- P11 steel
- DIN 933 galvanized steel
- Galvanized steel
- EPDM 70
- P01 steel
- C98 UNI 3823
- AISI 303 stainless steel
- ISO 7380 galvanized steel
- DIN 934 galvanized steel
- P11 steel
- DIN 933 galvanized steel locknuts

DIMENSIONS in mm.

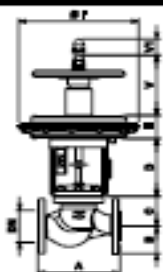

DN	Ø	A	B	C - Bonnet			D	V	V1	Actuator	E	Ø F
				Std	Finned	Bellows						
15	1/2"	130	47,5	49	181	181	147	166	11	T200	70	210
20	3/4"	150	52,5	58	190	190	147	166	11	T250	70	292
25	1"	160	57,5	68	200	200	147	166	11	T310	95	336
32	1.1/4"	180	70	70	202	202	147	166	19	T400	119	408
40	1.1/2"	200	75	82	214	214	160	166	19	T500	119	520
50	2"	230	82,5	86	218	218	160	166	19			
65	2.1/2"	290	92,5	111	309	309	160	166	28			
80	3"	310	100	135	333	333	160	166	28			
100	4"	350	118	160	363	363	204	166	28			

Specifications given are only indicative and not binding for the manufacturer who reserves the right to carry-out any modifications deemed necessary without prior notice. All data sheets by CONFLOW SpA, are available last update on our internet web site www.conflo.it.